

Socket circuits

Socket circuits are used to easily connect the wide range of electrical and electronic appliances to the mains supply using a plug and socket arrangement.

A flexible cord, normally not longer than 2 metres, connects the appliance to the plug top, which is then inserted into a conveniently located socket outlet.

BS 7671 Regulation 553.1.201 states that, 'Every socket outlet for household and similar use shall be of the shuttered type and, for an a.c. installation, shall preferably be of a type complying with BS 1363'.

Various current ratings are available but the 13 -ampere flat pin type is the most commonly encountered in Great Britain, with each plug top fitted with a cartridge fuse to BS 1362 to protect the flexible cord.

In order to enable appliances to be wired from a convenient and adjacent socket outlet, the outlets are wired to a ring radial circuit or to a radial final circuit.

As long as the circuit complies with the requirements of Table H2.1 in Appendix.

Table H2.1 – Final circuits using BS 1363 socket-outlets and connection units

Type of Circuit		Overcurrent protective device rating (A)	Minimum live conductor cross-sectional area (mm ²)		Maximum floor area served (m ²)
1	2		Copper conductor thermoplastic or thermosetting insulated cables	Copper conductor mineral insulated cables	
1	2	3	4	5	6
A1	Ring	30 or 32	2.5	1.5	100
A2	Radial	30 or 32	4	2.5	75
A3	Radial	20	2.5	1.5	50

The above reproduced from the IET On-Site Guide

Additionally, sockets outlets with a rating not exceeding 32A and mobile equipment with a current rating not exceeding 32A for use outdoors, must be protected by an RCD with a rating ($I_{\Delta n}$) not exceeding 30mA and an operating time not exceeding 300mS at $1 \times I_{\Delta n}$ (BS 7671 Regulation 411.3.3).

Radial final circuits

In a radial final circuit the cable comprising of a line, neutral and cpc 'radiates' from the consumer control unit (CCU) looping in and out of each socket outlet until the last outlet is reached and the circuit ends. The protective device and cable sizes can be found in Table H2.1 in Appendix H of the On-Site Guide but can be represented by the diagram below:

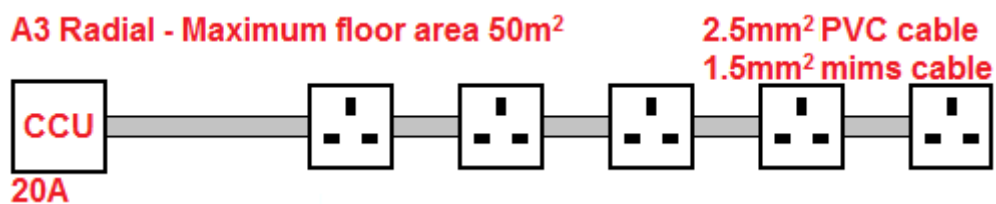
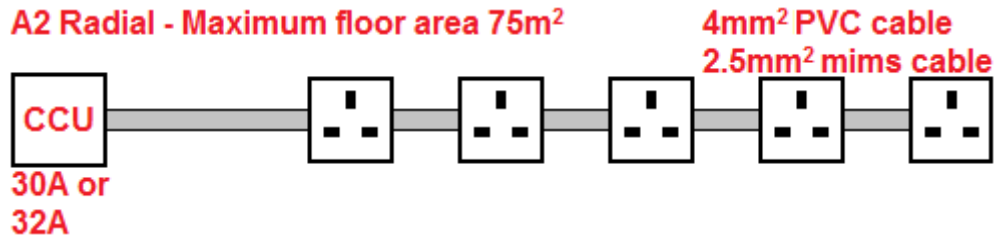

Ring final circuits

In a ring final circuit the cable comprising of a line, neutral and cpc starts at the consumer control unit (CCU) looping in and out of each socket outlet until the last outlet is reached and then a cable is brought back to the CCU where it is connected into the same terminals as the outgoing cable. The protective device and cable sizes can be found in Table H2.1 in Appendix H of the On-Site Guide but can be represented by the diagram below:

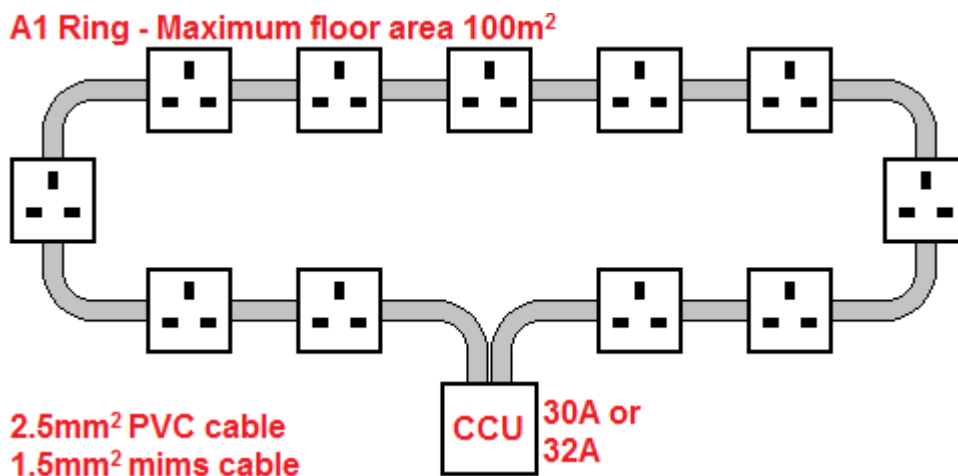

The standard ring final circuit utilises smaller conductors than the equivalent radial final circuit because the current going to each socket outlet comes from two directions, thus spreading the load. It is vitally important that the ring remains continuous; otherwise there is a risk of overloading one or more of the cables if the ring is broken. It is for this reason that a special test – the **continuity of ring final circuit conductors** test – must be carried out during the testing process to check that there are no breaks or interconnections to the ring.

Spurs from socket circuits

A spur is defined in Part 2 of BS 7671 as ‘a branch from a ring or radial final circuit’.

Further clarification on the arrangement of spurs for ring and radial final circuits can be found in Appendix 15 of BS 7671.

A spur can branch from the circuit by:

- using a joint box of the appropriate rating (must be accessible for inspection, testing and maintenance unless fitted with maintenance-free terminals)
- branching from an outlet connected directly into the final circuit.

The following points must be remembered when dealing with unfused spurs from ring final circuits.

- The number of unfused spurs must not exceed the number of outlets connected directly to the ring.
- Only one outlet is permitted on each unfused spur.
- An outlet is one single or one twin socket outlet or one piece of permanently connected equipment.

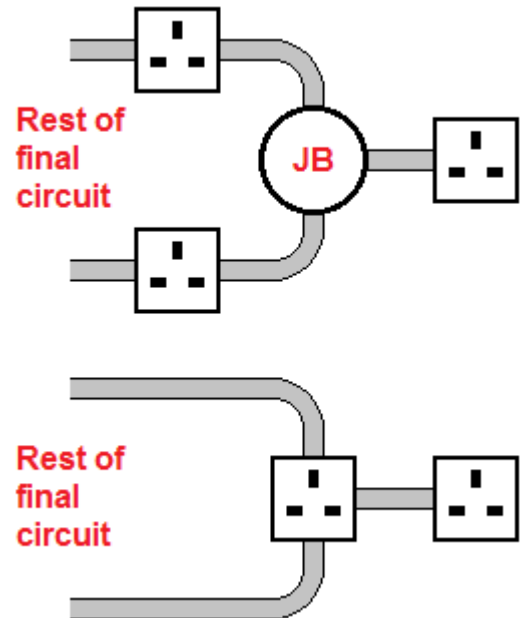

With fused spurs, that is, one fed from a fused connection unit, the number of outlets connected to the fused spur is not restricted.

General socket circuit considerations

- It is generally desirable to install at least two socket circuits in an installation so that if a fault occurs, there will still be some live outlets available in the premises. In a domestic house this usually means one circuit downstairs and one upstairs.
 - Where multiple circuits are installed, the number of outlets connected to each circuit should be roughly the same so that no circuit is greatly loaded compared to others.
 - Although socket outlet circuits allow an unlimited number of outlets to be installed, the total estimated current demand connected to the circuit should not exceed the rating of the protective device protecting that circuit.
 - A separate circuit for the kitchen, where there is likely to be a large number of appliances used simultaneously, should be considered.
-